

NS2212-15

High Precision N-Bit Delta-Sigma
Digital to Analog Converter

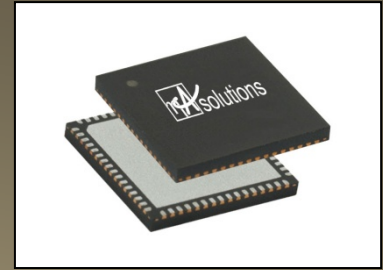

Features

- Scalable bandwidth and frequency
- Resolution is 14 bits at 135kHz bandwidth
- Resolution is 12 bits at 1MHz bandwidth
- Clock rate up to 40 MHz
- INL and DNL +/- 1 LSB noise
- 180nm digital CMOS process
- Single Supply Operation at 1.8V

Benefits

- Silicon proven design
- Ultra-low power consumption with 6mA at 1.8V per channel.
- Small silicon footprint at 0.28 sq mm with filter
0.206 sq mm without filter
- Scalable 180 nm CMOS

Applications

- GSM/EDGE
- CDMA 2000
- WCDMA
- Wireless Transmitters

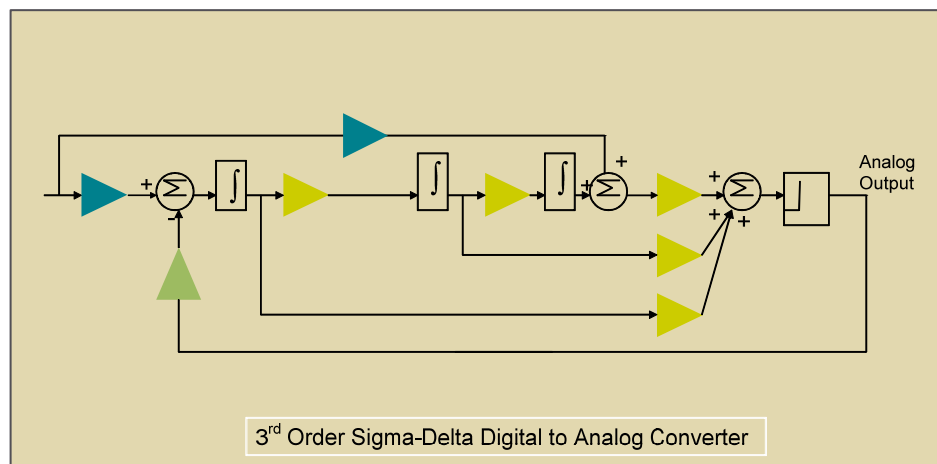

Description

The NanoAmp Solutions NS2212-15 is a general purpose programmable 3rd order Sigma-Delta digital to analog converter. The DACs are based on a multi-bit $\Sigma\Delta$ modulator that uses a programmable sampling frequency of 20MHz to 40MHz different performance and bandwidths. The output digital stream is a multi-bit analog signal representing 12-14 bits of resolution depending on the mode of the D/A converter.

An optional 3rd order Chebyshev reconstruction filter with 200kHz bandwidth is also available.

Electrical Characteristics

<i>Parameter</i>	<i>Conditions</i>	<i>Min</i>	<i>Typ</i>	<i>Max</i>	<i>Units</i>
Analog Supply Voltage		1.62	1.8	1.98	V
Digital Supply Voltage		1.62	1.8	1.98	V
Analog Supply Current			5		mA
Digital Supply Current			1		mA
Power Down Current			1		uA
Input Clock		20	26	40	MHz
Bandwidth		100	135	1000	kHz
Full-Scale Output Voltage			2		Vppd
SNR			70-80dB		
INL		-1		1	LSB
DNL		-1		1	LSB
THD			0.1		%
Turn on time			10		μ S
Operating Temperature		-30		85	C
Area Analog (no filter)			0.006		mm ²
Area Analog (w/200kHz filter)			0.18		mm ²
Area Digital			0.20		mm ²

Legend

O = Output
 I = Input
 IO = Input/Output
 P = Power (Supply or Ground)
 A = Analog Signal